



Building on The Cornerstone



PRINCE OF PEACE
CATHOLIC COMMUNITY

HONORARIUM & MEMORIAL
OPPORTUNITIES

DEAR PARISHIONERS,

I am so excited about the multifaceted construction process that we launched back in December 2021 and are currently in the midst of our parish facility transformation. This is a multi-tasker's dream because there are so many moving parts and varying aspects to this project.

We are now at the phase in our construction process where we need to solicit funding for the magnificent artwork and liturgical furnishings that will crown, or complete our project.

As I've reflected upon this entire endeavor, what has stood out to me the most is the sense that the sacred environment of our Prince of Peace worship space needs to be a place where people, upon entering the church, will immediately experience peace. I want all to experience peace in their heart, mind, soul, and then go forth and share it with others with all their strength. We all definitely need a place of peace...we need the Prince of Peace.

I think we can accomplish this objective!

As you review the artwork and sponsorship opportunities in this presentation, realize that these art pieces and furnishings are meant to facilitate this peace, contribute to an encounter with The Prince of Peace and draw others closer to our amazing Lord.

A parishioner recently shared with me that, and I quote: "Most people can't afford to put expensive artwork in their homes, but by putting it in their church home; they can all benefit from it and enjoy it together." This statement really resonated with me! This statement holds true for us now and for future generations to come.

Perhaps in a future presentation I'll share with you the genesis for using blue marble to accent our worship space, the placement of the baptismal font in alignment with the altar, ambo and tabernacle and the selection of the crucifix in the sanctuary. These vignettes are all providential moments in the development of this process.

Please pray about how you can participate in this phase of our project and how you can contribute to a monumental faith imprint in our Diocese and in Plano, Texas.

Thank you for your continued prayers and support during this time of transformation.

Fr. Michael

PAVERS - IN FRONT OF THE WELCOMING CENTER



Pavers (bricks) are a real popular item to offer because they memorialize a family, family member (living or deceased), friend, or even yourself, for years to come.

Our Pavers will adorn the walkway area outside the new Welcome Center. How fitting to have the engraved names of those who have touched others' lives there on the ground welcoming others to the parish. We anticipate these Pavers to go quickly as there are only 1,000 being offered. Pavers are 2" by 8".

HONORARIUM AND MEMORIAL OPPORTUNITIES

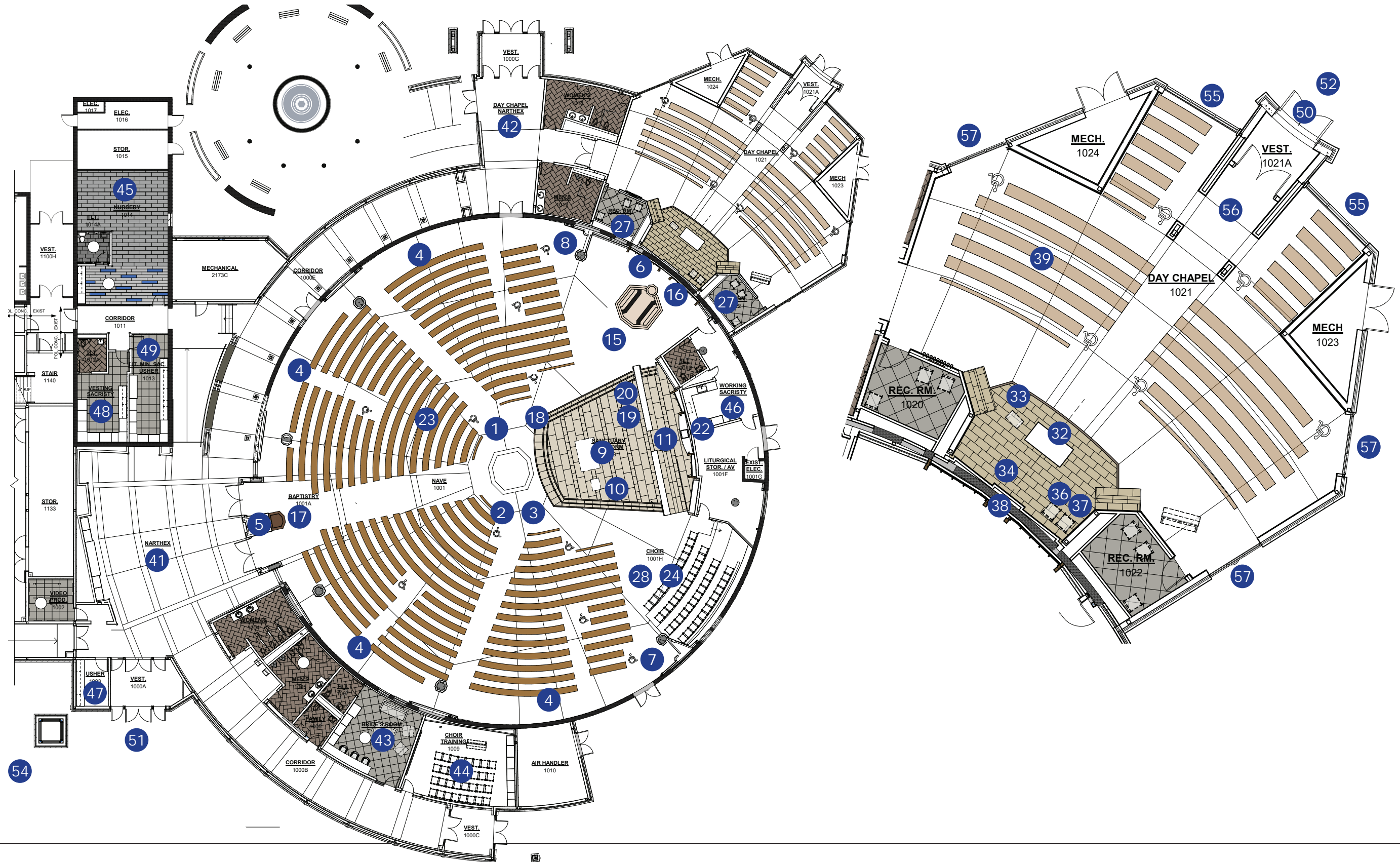

CHURCH LITURGICAL ART

- 1 Cupola Mosaic - Holy Spirit
 - 1a Dove - Mosaic
 - 1b Gifts of the Holy Spirit - Mosaic (8)
 - 1b.1 - Wisdom
 - 1b.2 - Understanding
 - 1b.3 - Counsel
 - 1b.4 - Fortitude
 - 1b.5 - Knowledge
 - 1b.6 - Piety
 - 1b.7 - Fear of God
- 2 Cupola Frosted Stained Glass Windows (18)
- 3 Cupola Side Panel Mosaic - Tongues of Fire (8)
- 4 Stations of the Cross - Mosaic (14)
 - 4a - 1st Station: Jesus is condemned to death
 - 4b - 2nd Station: Jesus carries His cross
 - 4c - 3rd Station: Jesus falls the first time
 - 4d - 4th Station: Jesus meets His Mother
 - 4e - 5th Station: Simon of Cyrene helps Jesus to carry His cross
 - 4f - 6th Station: Veronica wipes the face of Jesus
 - 4g - 7th Station: Jesus falls the second time
 - 4h - 8th Station: Jesus meets the women of Jerusalem
 - 4i - 9th Station: Jesus falls a third time
 - 4j - 10th Station: Jesus is stripped of His garments
 - 4k - 11th Station: Jesus is nailed to the cross
 - 4l - 12th Station: Jesus dies on the cross
 - 4m - 13th Station: The body of Jesus is taken down from the cross
 - 4n - 14th Station: Jesus is laid in the tomb
- 5 Blessing Font - Mosaic
- 6 Baptistry Ambry - Mosaic
- 7 Shrine of Saint Joseph with toddler Jesus - Marble
- 8 Shrine of the Blessed Mother with infant Jesus - Marble

CHURCH LITURGICAL ITEMS

- 9 Altar
- 10 Ambo
- 11 Tabernacle and House
- 12 Sacristy Lamps
- 13 Altar Candle Sticks (4)
- 14 Paschal Candle Stand
- 15 Baptismal Font (Marble)
- 16 Baptismal Infant Font (Marble)
- 17 Blessing Font (Marble)
- 18 Sanctuary Platform Stair Trim Nosing (Blue Marble)
- 19 Presider's Chair
- 20 Concelebrant Chairs (2 seats)
- 21 Credence and Gift Tables (2 each)
- 22 New Crucifix
- 23 Pews with Kneelers (56)
- 24 Choir Chairs (58)
- 25 Shrine Kneelers (2)
- 26 Wedding Kneeler
- 27 Reconciliation Screen and Kneeler (2)
- 28 Organ (100)
- 29 Video Screen System (50)
- 30 Sound System (50)
- 31 Hearing Impaired System (9)

CHAPEL LITURGICAL ITEMS

- 32 Chapel Altar
- 33 Chapel Ambo
- 34 Chapel Tabernacle Marble Wall
- 35 Chapel Sacristy Lamps
- 36 Chapel Presider's Chair
- 37 Chapel Concelebrant Chair (1)
- 38 Chapel New Crucifix
- 39 Chapel Pews with Kneelers (20)
- 40 Chapel Credence Tables

CHURCH ROOMS

- 41 Church Narthex
- 42 Chapel Narthex
- 43 Bride Rooms
- 44 Choir Rehearsal Room
- 45 Children's Formation Room
- 46 Work Sacristy
- 47 Usher Ministry
- 48 Priest Vesting Sacristy
- 49 Liturgical Ministry Sacristy

EXTERIOR

- 50 Large Cross on Chapel
- 51 Church Metal Front Doors (4)
- 52 Chapel Metal Front Doors (2)
- 53 Large Cross on Welcoming Center
- 54 Bell Tower

CHAPEL LITURGICAL ART

- 55 The Evangelists - Facade stained glass windows (4)
 - 55a St. Matthew
 - 55b St. Luke
 - 55c St. John
 - 55d St. Mark
- 56 Resurrection - Interior Chapel back wall - Mosaic
- 57 Creation - Stained glass windows (3 windows - 27 panels)

1 CUPOLA MOSAIC - HOLY SPIRIT



The Dove Mosaic/Cupola:
This fine work of art will clearly be our stand out piece of Sacred Art at Prince of Peace! With the Dove being the symbol of Peace and the Holy Spirit, we have fashioned it in the spirit of Bernini's dove that is displayed at St. Peter's Basilica in Rome. The rays bursting forth from the dove show the power of the Holy Spirit in our lives. Likewise, the Gifts of the Holy Spirit surrounding this image calls to mind our own Sacrament of Confirmation.

1a DOVE - MOSAIC

1b GIFTS OF THE HOLY SPIRIT - MOSAIC (8)



2 CUPOLA CLOUD STAINED GLASS WINDOWS (18)

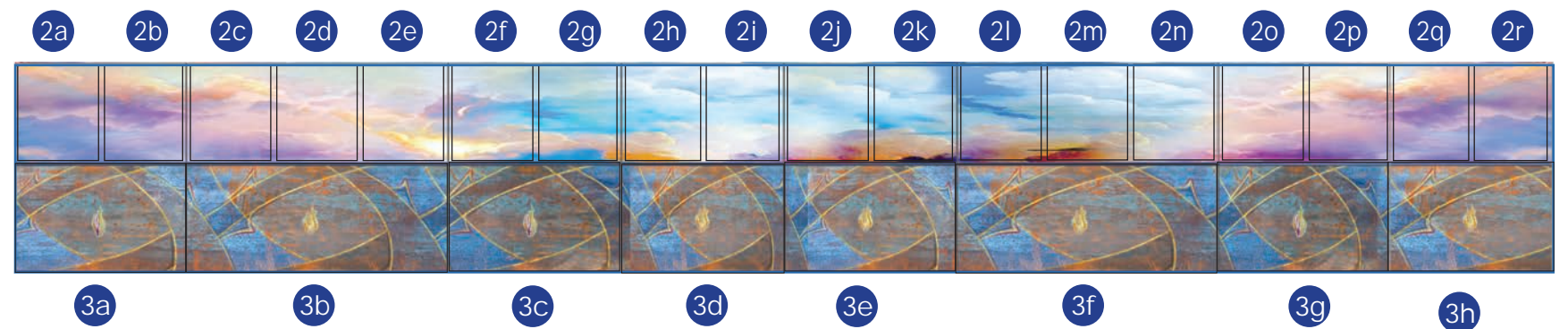

3 CUPOLA SIDE PANEL MOSAIC - TONGUES OF FIRE (8)

The Stained Glass Windows present a soft, yet bold, scene of the sky of the heavens. Reminiscent of the significance of the Cloud of God encircling Moses on the mountain or covering the tent of the Ark, we see that the Cloud of God encircles us in our worship of Him. This motif, too, is a nod of appreciation to Fr. Jim and his original vision for Prince of Peace Catholic Community.

The Mosaic Panels will depict the Tongues as of fire that descended upon the disciples on Pentecost. Also, the colors and action expressed by the gold lines and blue hues will directly link these mosaics to the same colors and action used in the wrap around Stations of the Cross.

4 STATIONS OF THE CROSS - MOSAIC (14)

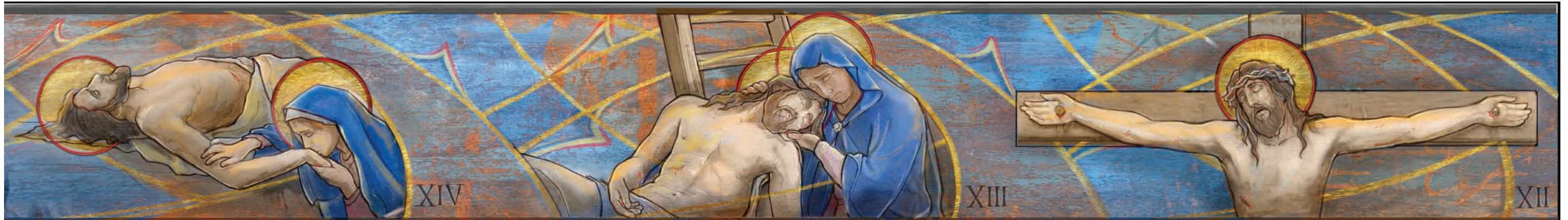

- 4a 1st Station: Jesus is condemned to death
- 4b 2nd Station: Jesus carries His cross
- 4c 3rd Station: Jesus falls the first time
- 4d 4th Station: Jesus meets His Mother
- 4e 5th Station: Simon of Cyrene helps Jesus to carry his cross
- 4f 6th Station: Veronica wipes the face of Jesus
- 4g 7th Station: Jesus falls the second time
- 4h 8th Station: Jesus meets the women of Jerusalem
- 4i 9th Station: Jesus falls a third time
- 4j 10th Station: Jesus is stripped of his garments
- 4k 11th Station: Jesus is nailed to the cross
- 4l 12th Station: Jesus dies on the cross
- 4m 13th Station: The body of Jesus is taken down from the cross
- 4n 14th Station: Jesus is laid in the tomb

The Stations of the Cross will certainly bring a unique visual presentation of the Stations. With its realism and action we will be able to enter into the Lord's passion in a profound and powerful way. The gold swirling lines that were mentioned above under the Cupola Mosaics, signify the crown of thorns and, again, connect the mosaics together.

CHURCH LITURGICAL ITEMS - THE SANCTUARY



As you can see from this rendering, the Sanctuary is noble but simple. You'll notice the Baptismal Font is in vertical alignment with the Altar and Ambo as baptism is the entry way to the Word of God in the scriptures and the Son of God in the Eucharist. You'll notice the subtle blue marble accents used, again to draw us into an experience of personal and communal peace.

9 ALTAR TABLE



AZUL CIELO MARBLE
WHITE CARRARA MARBLE

At the Eucharist, the liturgical assembly celebrates the ritual sacrificial meal that recalls and makes present Christ's life, death, and resurrection, proclaiming "the death of the Lord until he comes." The altar is "the center of thanksgiving that the Eucharist accomplishes" and the point around which the other rites are in some manner arrayed. *BLS*

10 AMBO



The central focus of the area in which the word of God is proclaimed during the liturgy is the ambo. The design of the ambo and its prominent placement reflects the dignity and nobility of that saving word and draws the attention of those present to the proclamation of the word. *BLS*

11 TABERNACLE AND HOUSE

The general law of the Church provides norms concerning the tabernacle and the place for the reservation of the Eucharist that express the importance Christians place on the presence of the Blessed Sacrament.

To provide for the security of the Blessed Sacrament the tabernacle should be "solid," "immovable," "opaque," and "locked." The tabernacle may be situated on a fixed pillar or stand, or it may be attached to or embedded in one of the walls. A special oil lamp or a lamp with a wax candle burns continuously near the tabernacle as an indication of Christ's presence. *BLS*

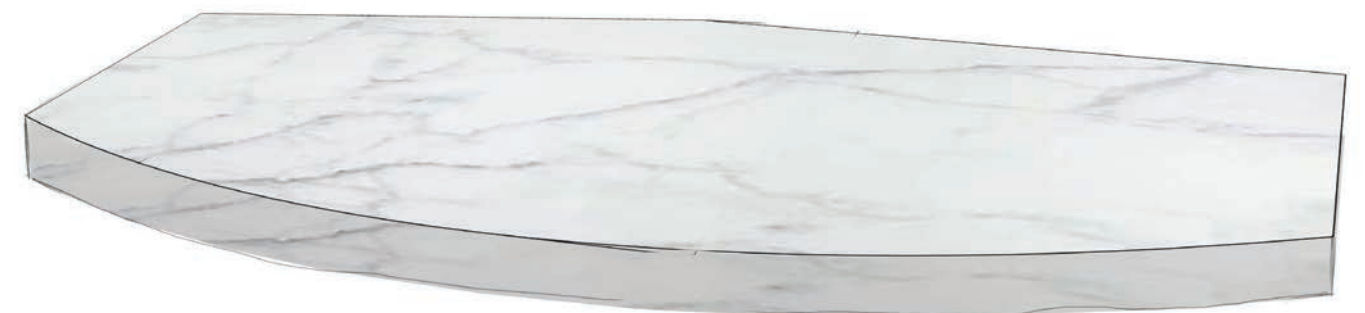

12 SANCTUARY LAMPS

13 ALTAR CANDLE STICKS (4)

- 19 PRESIDER'S CHAIR
- 20 CONCELEBRANT CHAIRS
(2 SEATS)
- 21 CREDENCE AND GIFT TABLES
(2 EACH)

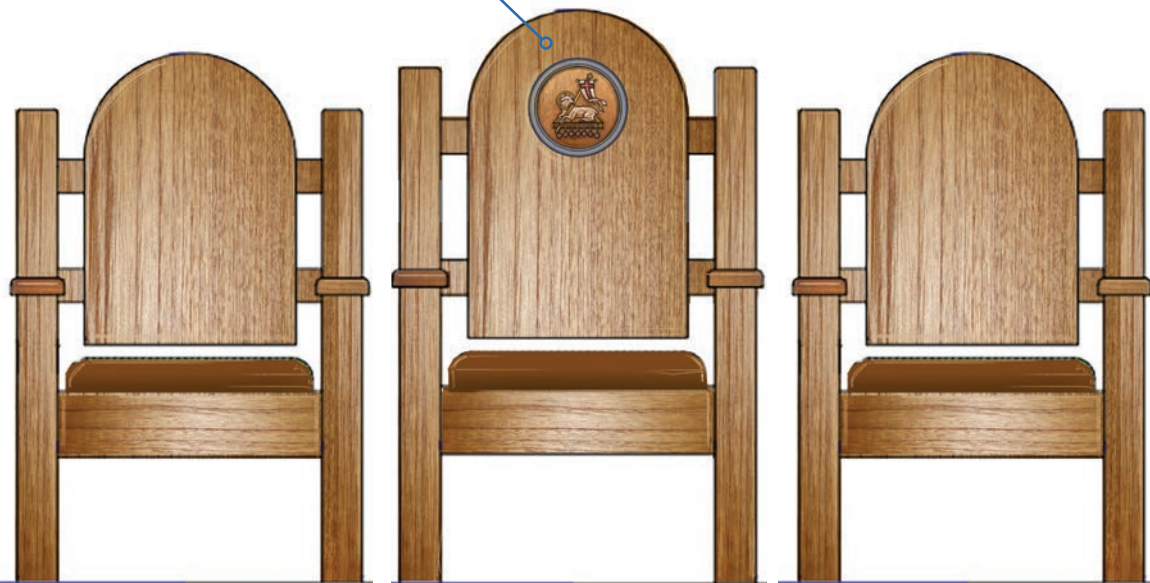

The Presiders Chair will have an image of the Lamb.
The chair of the priest celebrant stands "as a symbol of his office of presiding over the assembly and of directing prayer." *BLS*

22 CRUCIFIX

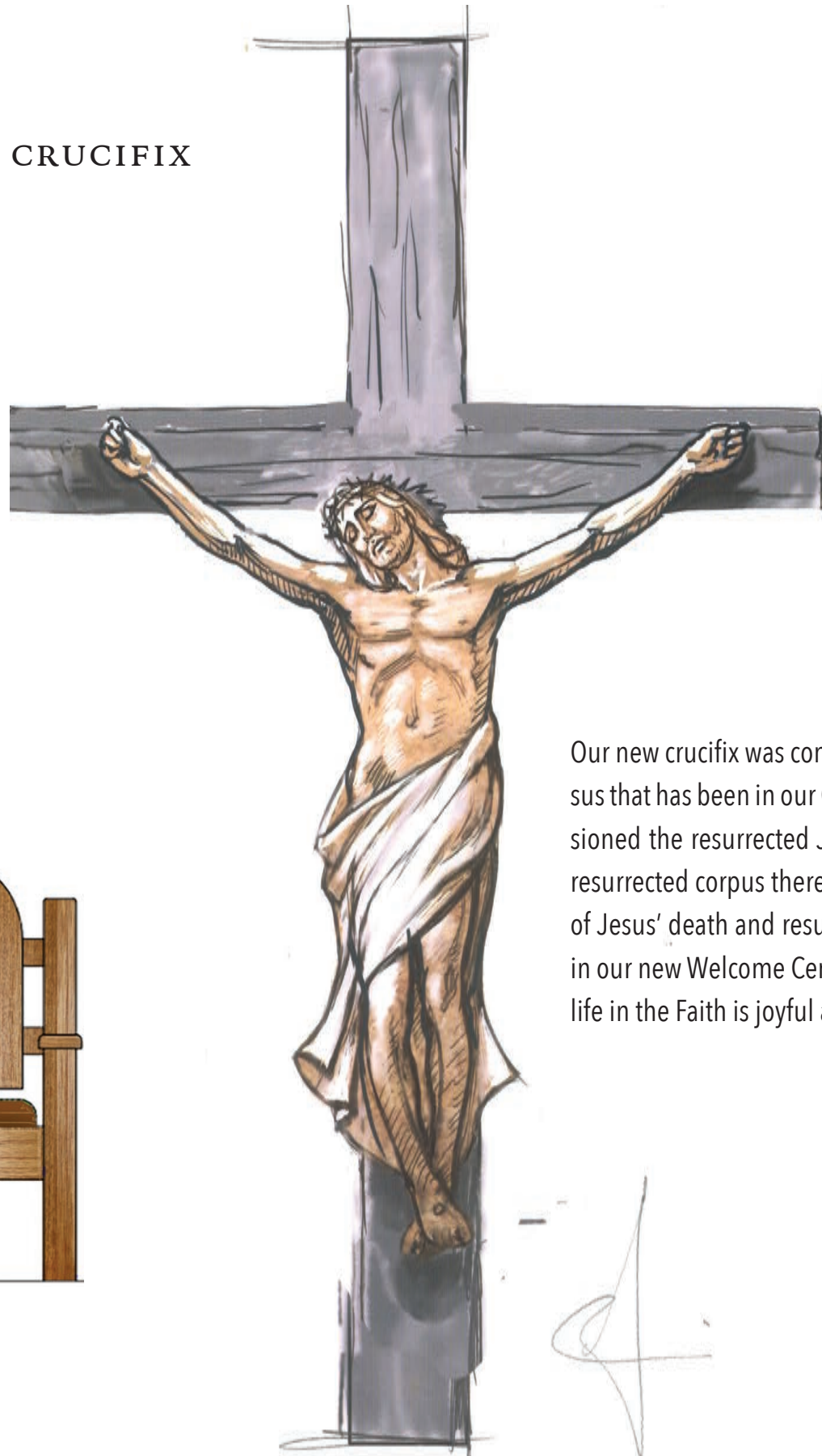

Our new crucifix was commissioned to the same artist that made the resurrected Jesus that has been in our Church. This is a nod of appreciation to Fr. Tom who commissioned the resurrected Jesus. We wanted the crucified corpus (body) to match the resurrected corpus thereby making the connection between the two significant acts of Jesus' death and resurrection. We plan to have the resurrected corpus mounted in our new Welcome Center as a reminder that we are a resurrected people and that life in the Faith is joyful and celebratory life.

- 7 SHRINE OF SAINT JOSEPH WITH TODDLER JESUS - MARBLE
- 8 SHRINE OF THE BLESSED MOTHER WITH INFANT JESUS - MARBLE

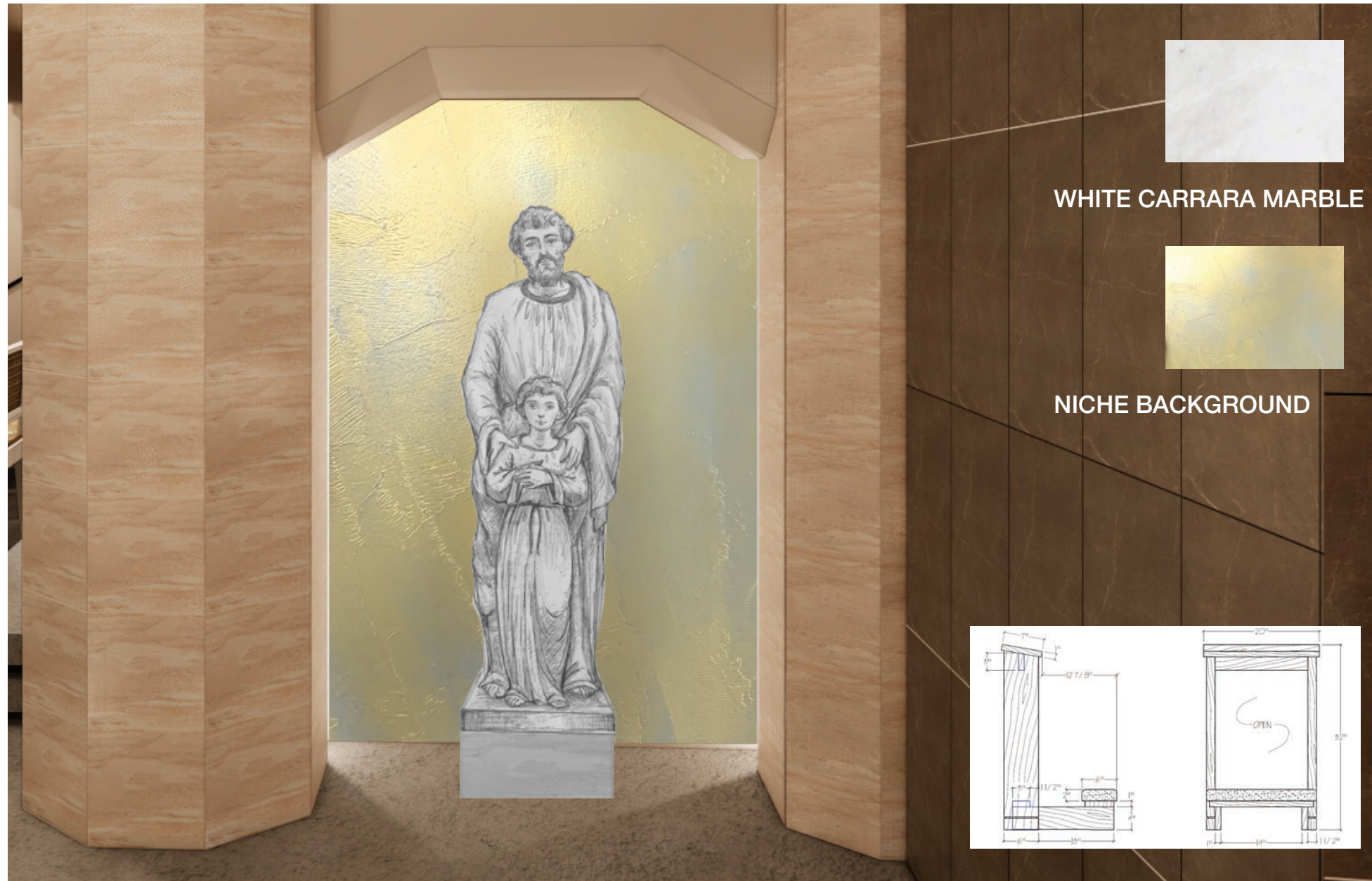

The Statues of Mary and Joseph with Jesus:

Inside the church we will have two statues for prayer and intercession on either side of the church. Mary, depicted with the baby Jesus, and Joseph depicted with the adolescent Jesus. The transition from infancy with Mary to young adulthood with Joseph captures the progression of growth in the life of Jesus.

BAPTISTRY, BLESSING FONT AT ENTRANCE AND MOSAICS



5 BLESSING FONT - MOSAIC

6 BAPTISTRY AMBRY - MOSAIC

These two Mosaics serve to heighten the importance of the Blessing Font and the Baptismal Font (as well as the Holy Oils). By bringing these two significant items to an esteemed level the Mosaics then serve to connect them to the other significant Sacred Art pieces throughout the church space.

17 BLESSING FONT (MARBLE)

The Blessing Font will be positioned at the entrance into the church and will be made of the same materials as the Baptismal Font, the Altar, the Ambo and Tabernacle enclosure thereby connecting the parishioner to his or her own baptism. By having one common holy water font to bless ourselves upon entrance to the church we further acknowledge our oneness with our Lord and with each other by way of our baptism.

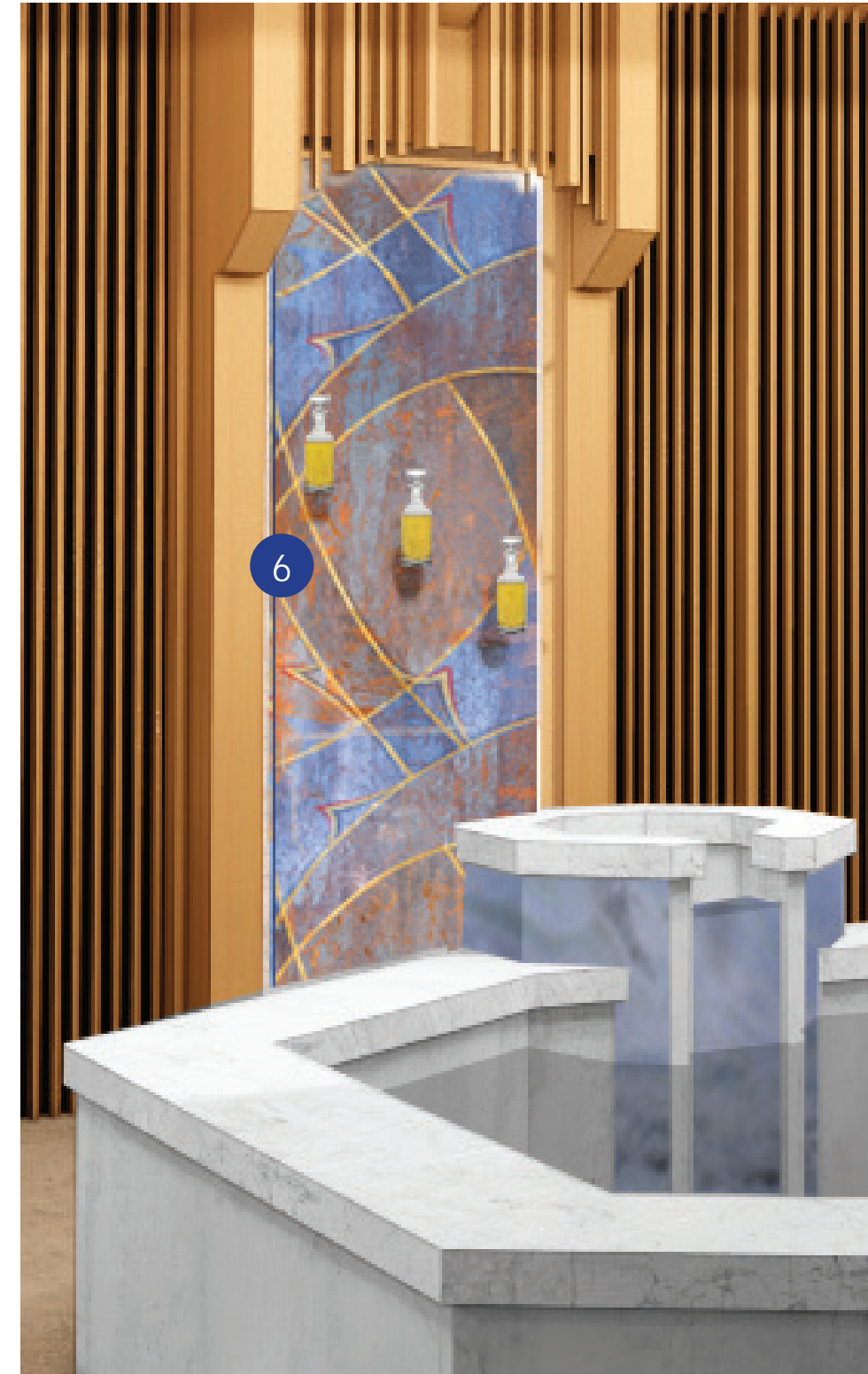

14 PASCHAL CANDLE STAND

15 BAPTISMAL FONT (MARBLE)

16 BAPTISMAL INFANT FONT (MARBLE)



AZUL CIELO MARBLE
WHITE CARRARA MARBLE

The Baptismal Font is made of White Carrara Marble from Italy and highlighted by Azul Cielo Marble from Argentina. "Azul Cielo" is translated into English as "Blue Sky" or "Blue Heaven". With the color blue being the international color for peace, we have utilized this Argentinian marble to help accentuate the major liturgical furnishings, i.e., the Font, the Altar, the Ambo and the Tabernacle. The Baptismal Font is in an octagon shape which matches with the Cupola's octagon form. The very early Christians borrowed this shape from the Jewish cleansing rituals. The number eight had become the capstone to the perfect number of seven, the biblical number of days associated with the creation of the world.

WOOD LITURGICAL FURNITURE

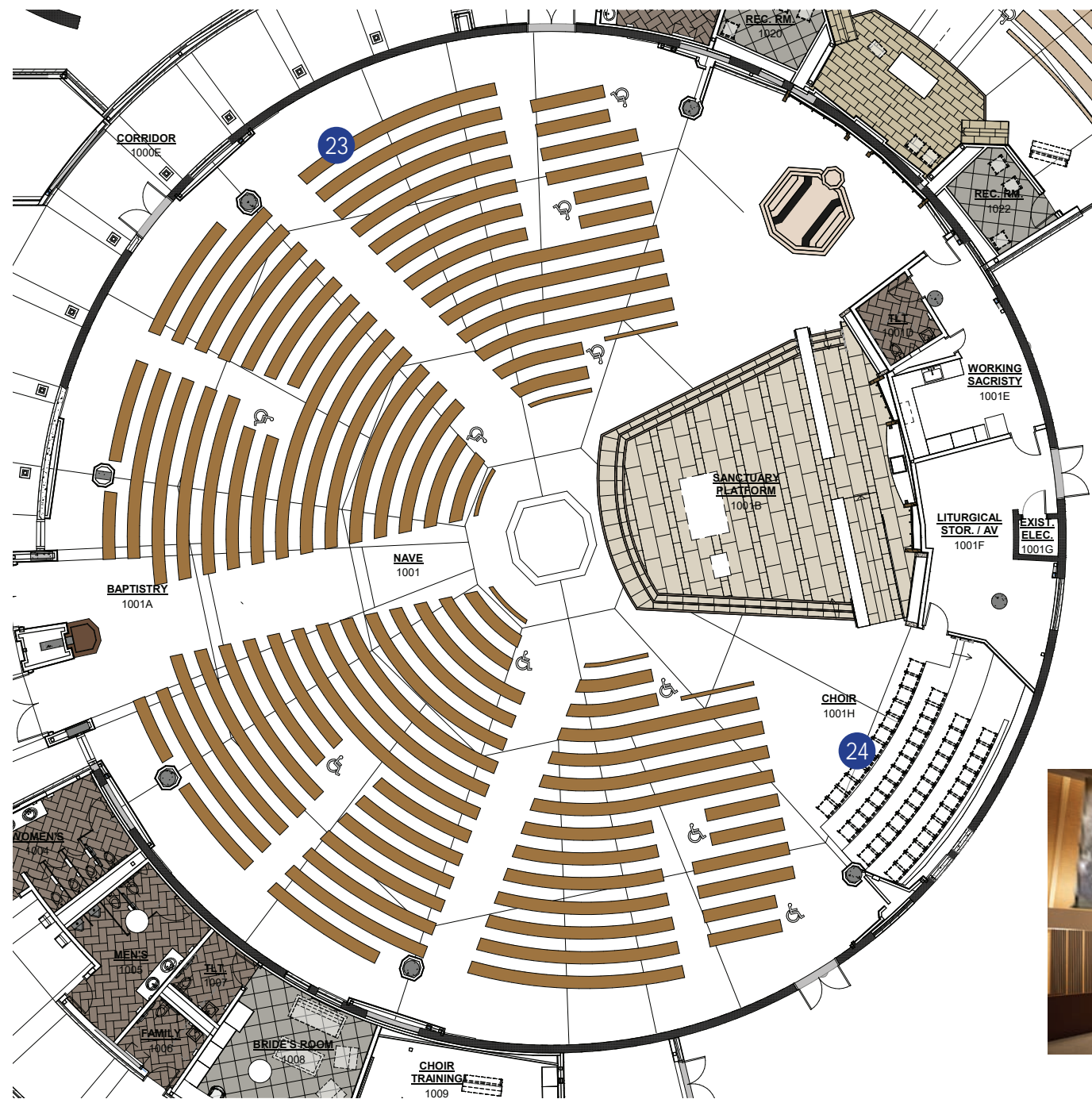

23 PEWS WITH KNEELERS (56)

24 CHOIR CHAIRS (58)



25 SHRINE KNEELERS (2)

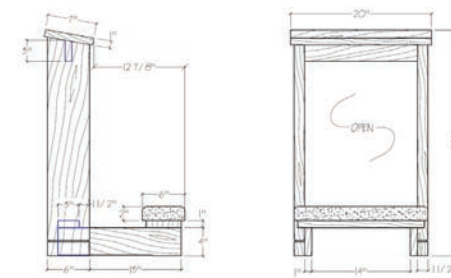

29

29 VIDEO SCREEN SYSTEM (50)

28 ORGAN (100)



26 WEDDING KNEELER

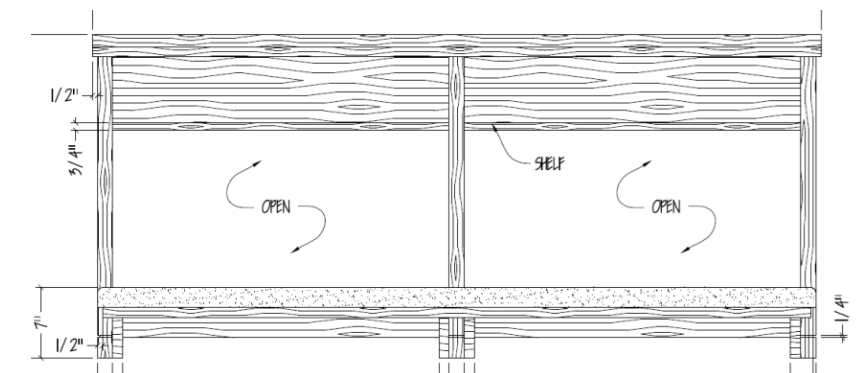

27 RECONCILIATION SCREEN AND KNEELER (2)

30 SOUND SYSTEM (50)

31 HEARING IMPAIRED SYSTEM (9)

EXTERIOR

The relocation of the bell tower at the front entrance of the church with a new brick and stone facade in honor of Fr. Jim Balint.

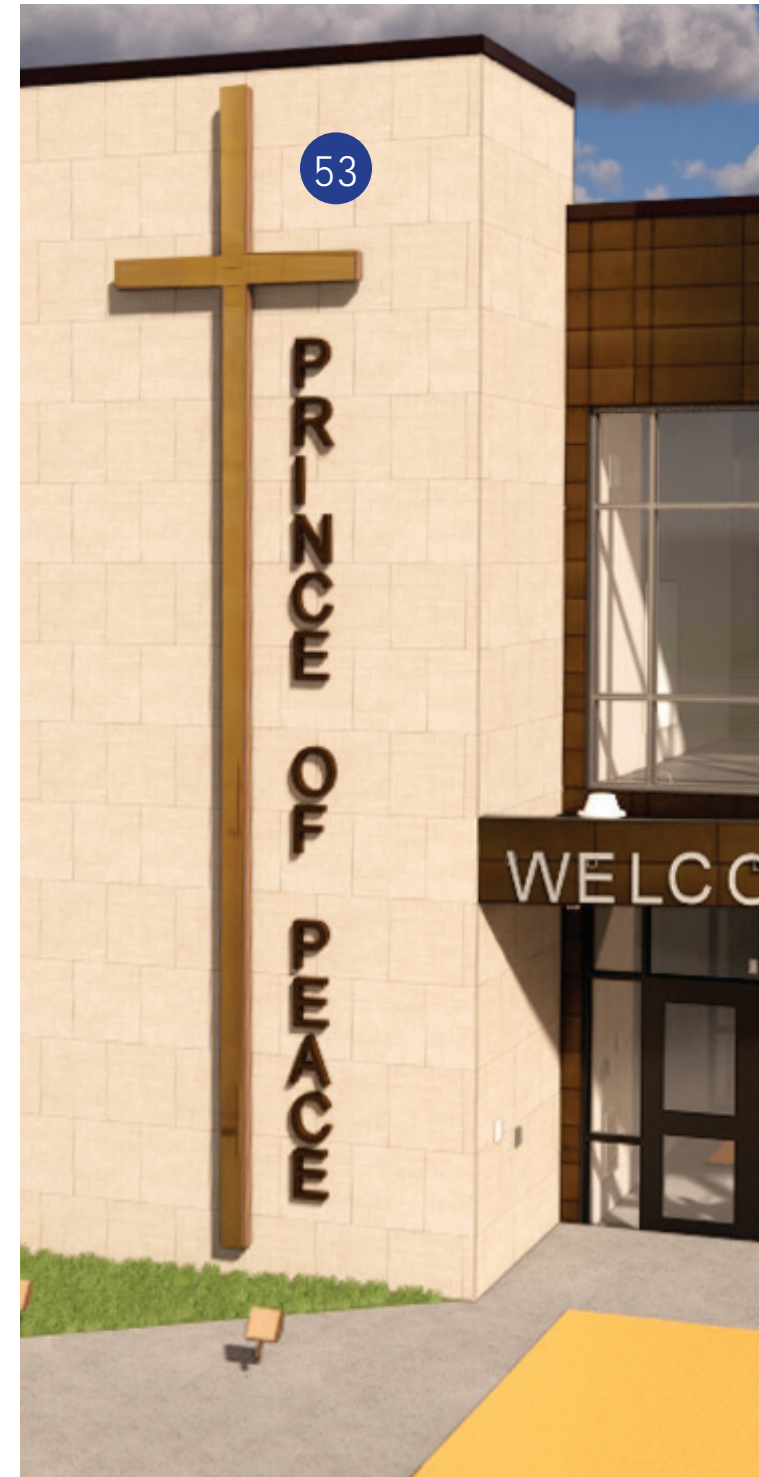

CHAPEL LITURGICAL ITEMS

32 CHAPEL ALTAR



33 CHAPEL AMBO



34 CHAPEL TABERNACLE MARBLE WALL

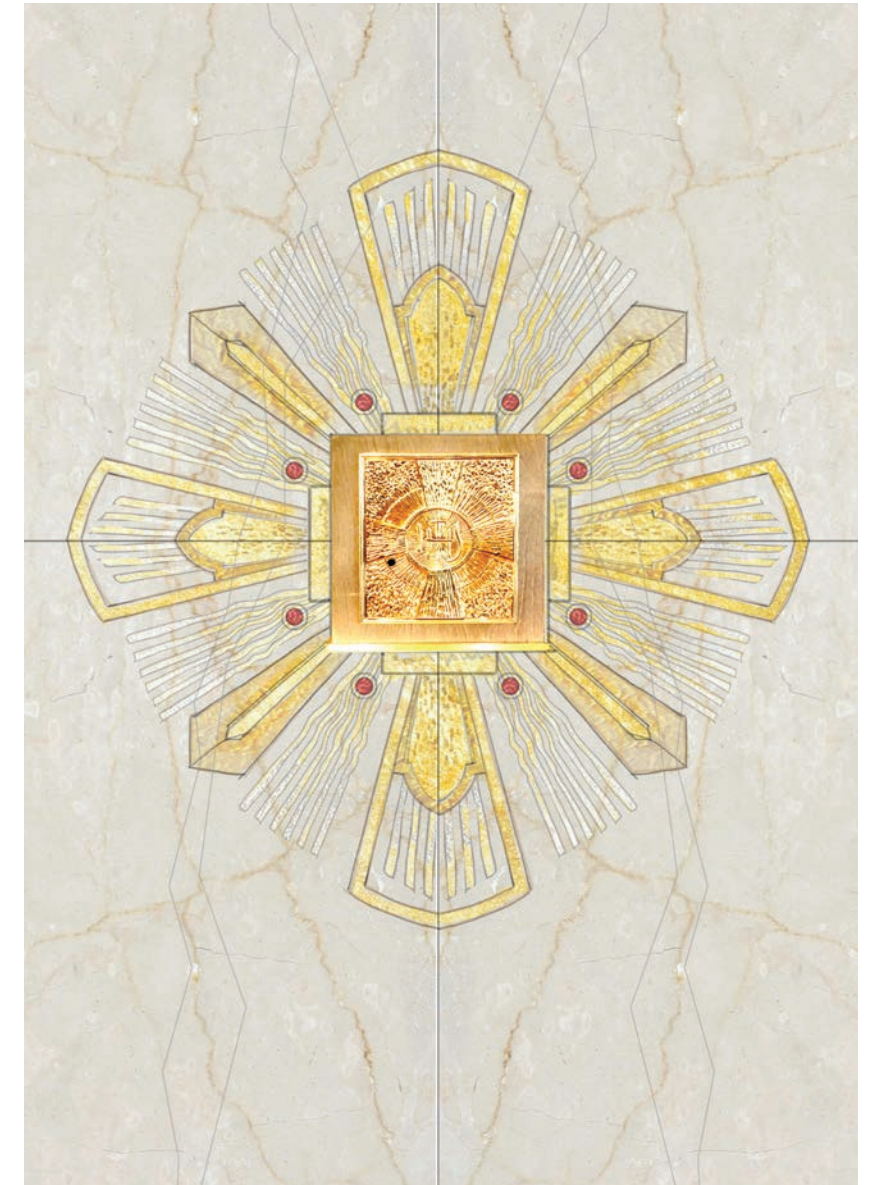

Botticino marble background,
Various tones of gold and silver mosaic inlays

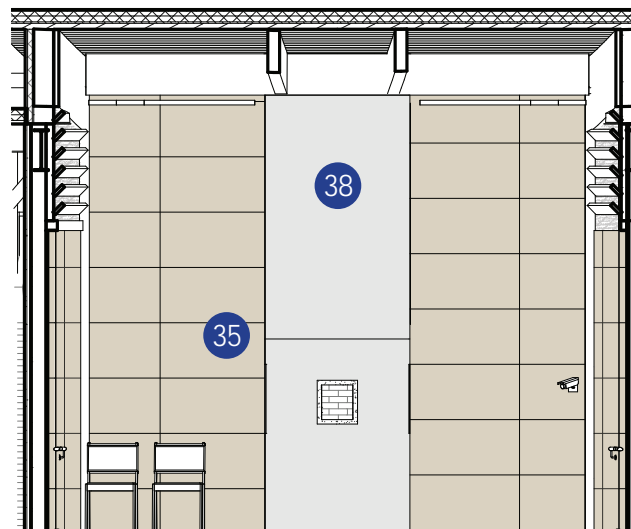

- 35 CHAPEL SACRISTY LAMPS
- 36 CHAPEL PRESIDER'S CHAIR
- 37 CHAPEL CONCELEBRANT CHAIR (1)
- 38 CHAPEL NEW CRUCIFIX
- 39 CHAPEL PEWS (20)
- 40 CHAPEL CREDENCE TABLES

CHAPEL LITURGICAL ART

55 THE EVANGELISTS FACADE STAINED GLASS WINDOWS (4)

55a SAINT MATTHEW

55b SAINT LUKE

55c SAINT JOHN

55d SAINT MARK

56 RESURRECTION INTERIOR CHAPEL BACK WALL MOSAIC



57 CREATION - STAINED GLASS WINDOWS (3 WINDOWS - 27 PANELS)

Day 1: God divided the light from darkness. Having brought forth Heaven and a formless, water-covered Earth, He created the light.

Day 2: God divided the waters from above and below to create the firmament of Heaven.

Day 3: God created dry land, then grass, flowers and trees.

Day 4: God created the sun, the moon and the stars.

Day 5: God created the birds and the fish.

Day 6: God created the animals and then man.

Day 7: On the seventh day, God rested.

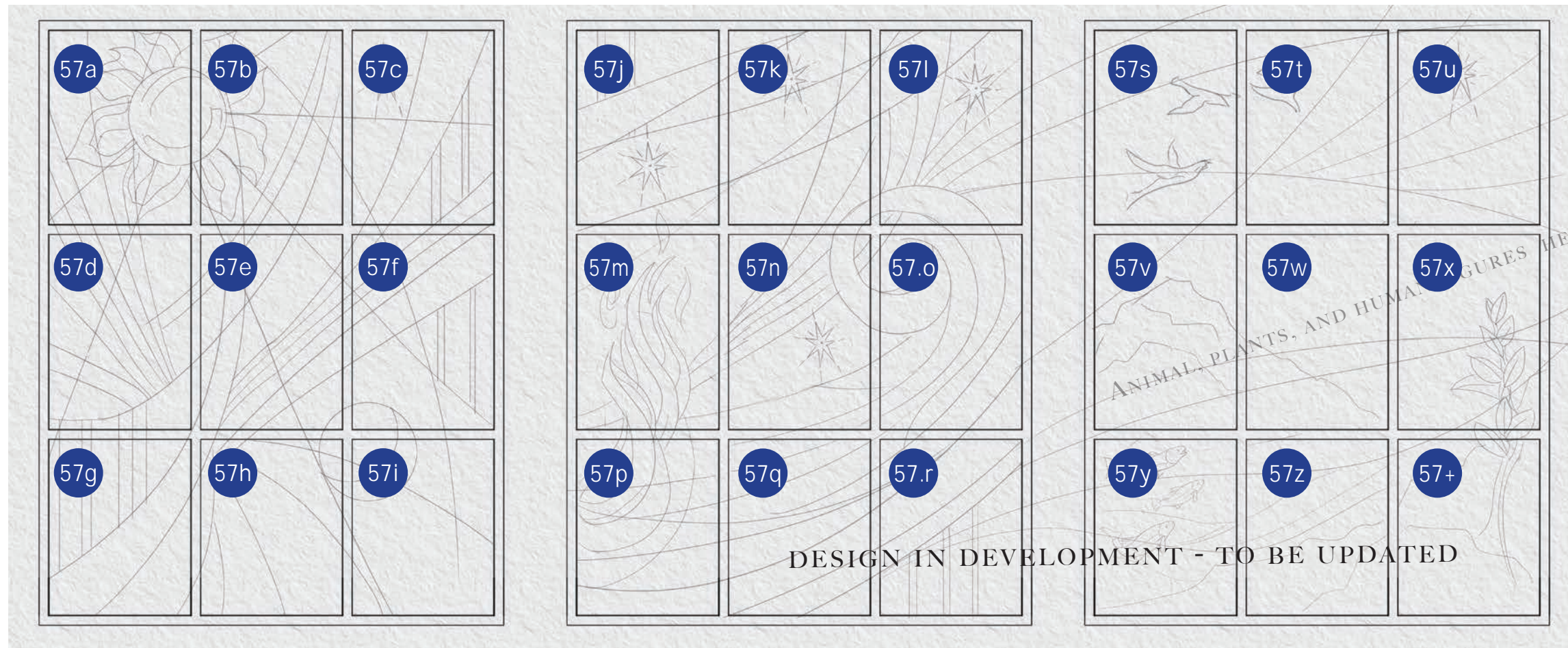

Frequently Asked Questions

Prince of Peace Building Campaign

Yes! I would like to reserve an art piece as an honorarium. What's my next step?

Please contact Marty Dama at mdama@popplano.org or (phone) to ensure that your piece is available. After speaking with Marty, submit the Honorarium & Memorial Commitment Card with your 25% down payment.

When are payments due?

A 25% deposit is necessary to reserve your memorial item. The remaining payments are due in five quarterly payments at the following payment schedule: down payment, October 2022, January 2023, April 2023, July 2023, and October 2023.

Can I make my payments according to a different schedule?

We want to be as accommodating as possible; however, our quarterly payment schedule ensures that our artisans are paid for their work in a timely manner. If your circumstances require that you use a different payment schedule, please reach out to Marty Dama to discuss your proposed schedule.

Can multiple families give to the same item?

Yes, multiple families can pool resources to sponsor a specific item. Items are limited to one donor or donor group. When making your deposit, let Marty Dama know if your honorarium is part of a group.

How do I know what items are still available?

We will try to update our online PDF each time an item is reserved; however, the best way to ensure that your item is available is by contacting Marty Dama.

My employer has a gift-matching program. How can I learn more?

Additional support to the campaign may be provided through the generosity of corporate matching gift programs. Talk to your employer about their matching benefits program to learn what paperwork will be required and their timeline for payments. Once you have this knowledge, please contact Marty Dama to secure your piece and ensure that Prince of Peace provides necessary information to your employer.

When will the new Church be complete?

The completion date for the new Church depends on how quickly pledges are received. Some of the art, like our mosaic for the Stations of the Cross, takes a year to make! As soon as funding is secure for these art pieces, we will contact the artists to commission them. We are hopeful to be in the new sanctuary by Christmas of 2023.



HONORARIUM & MEMORIAL COMMITMENT CARD

I/We support the "Building on The Cornerstone" campaign and would like to ensure the success of this effort by making a commitment / gift to the campaign as follows:

Please note my/our total commitment/gift of \$_____

SELECTED ITEM(S) TO BE MEMORIALIZED:

DEDICATED TO / IN MEMORY OF / IN HONOR TO:

Donor information (please print)

First Name: _____ Last Name: _____

Spouse Name (if applicable): _____

Address: _____ City, State, Zip: _____

Email Address: _____ Phone Number: _____

I/We will allow public knowledge that I/we have given but not the amount of the gift. I/We wish to remain anonymous.

Signature: _____ Date: _____

Payment Schedule: a 25% deposit and five quarterly payment (down payment, Oct 2022, Jan 2023, April 2023, July 2023, Oct 2023).

Thank you for believing in and supporting the POP Building Campaign

Our Goal is 100% participation. Please, return your commitment card to Prince of Peace Catholic Community by _____. Please, make checks payable to Prince of Peace Building Campaign.

For more information or for payment assistance,

please contact **Marty Dama at (469) 693-8096. Email: mdama@popplano.org**

Prince of Peace Catholic Community is a 501(c)3 nonprofit organization. Gifts to the campaign are tax-deductible as allowed by law.



Gracious God,

We, your sons and daughters, thank you for all the blessings you have bestowed upon this community.
By the power of your Holy Spirit, guide this process of renewal.

May all the bricks laid, nails driven, and wood placed represent each of us
as the living stones of your Church, and upon the foundation laid by your Son, Jesus,
provide for us and future generations buildings that will allow all to grow in grace, wisdom, and love.
Through the intercession of our mother, Mary, all the angels and saints,
may the Prince of Peace bless this undertaking and bring your will to completion.

Amen.

www.popplano.org

5100 W PLANO PKWY
PLANO, TX 75093
(972) 380-2100